

TUNING INSTRUCTIONS (CARBURETOR IS PRE-SET)

Thank you for purchasing a Lectron Carburetor. With a basic understanding of the Lectron system, and the following instructions, you will be able to tune your carburetor in a very short time.

Understand that Lectron uses a single fuel metering device. This one simple device takes the place of a pilot jet, intermediate circuit, and main jet found in a conventional carburetor. This one metering rod is equivalent to approximately 10 main jets in a conventional carburetor.

To understand this fuel metering rod, see this picture below:

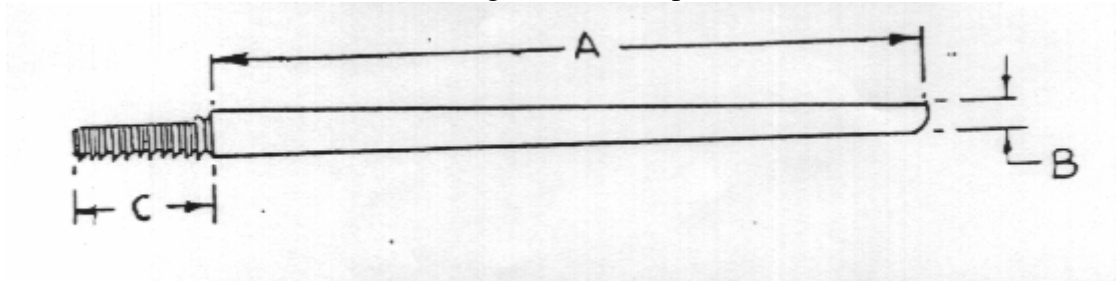

Dimension (A) will be the same on all metering rods that have the “XL” at the end of the prefix. (This means extra long) The extra long rod will fit into all Lectrons from 30mm to 48mm. This diameter is the length of the taper.

Dimension (B) will vary according to the number of the metering rod. A higher number would mean the dimension would be smaller, making the metering rod richer. Just a conventional carburetor, a smaller number jet is leaner than a larger number jet.

Dimension (C) these are the adjusting threads, which will remain the same on all metering rods.

Basically, you dial in the low speed by turning the metering rod. Turning the rod in or clockwise into the slide would make the low end speed richer. By turning the needle out or counter clockwise from the slide, this will make the low speed leaner. Never adjust the rod to try to active top end mixture; the rod adjustment is for adjusting idle and low speed only.

When the engine will start, idle, and take throttle small throttle revs, you are ready to test high speed test.

It's best to take the vehicle for a ride or better yet dyno test. The top end test is to determine how lean or rich the engine is for your existing jetting. To determine top end

mixture it is best to have an O2 sensor with a Dyno. Lectron carburetors are a performance carburetor so performance O2 is usually between 13 to 1 and 12.5 to 1. If you are doing a spark plug tests with out a Dyno, spark plugs should have a very light tan color at top check. (with race fuel you should have a light gray) If the top end is too lean go to a bigger power jet. If the top end is too rich change to a smaller power jet. It's as simple as that.

If the low end is satisfactory but the top end is too lean or too rich and you can not achieve the proper jetting by changing to a different power jet then that is the time you would need to change to a different metering rod. If you have to do this you must follow the metering rod chart to determine what to change to.

EXAMPLE: You have a 4-1XL rod in your carburetor and a #100 power jet but the top end is still to lean. Change to a 5-1XL rod and go down to a #60 power jet you will now be richer and still have more jetting room to go for weather condition changes.

The Lectron Metering rods are determined by 2 numbers, first number is the top end. The second number is the idle and low speed. Example: 4-1XL rod, 4 is the top end fuel and 1 is the low end fuel. The higher the number the richer the fuel into the engine is. The top end numbers go up to 20 and the low end numbers go to 4. There also some custom metering rods made for our some of our high end tuners. If you have rods with other numbers or letters you must call Lectron Inc. to find out what they are.

EXAMPLE: FBG-2XL or PE-1XL etc. these are custom made rods.

The XL at the end of each rod is aberration for extra long. This tells us that the rod will work in carbs from 30mm to 48mm. (older rods have no marking or just an L) these rods are no longer made.

Be sure that you engine is in good condition, the ignition timing is set correctly, the valves are adjusted and the compression is up. Make sure there are no obstructions in the exhaust system. If all these things are correct, the carburetor will be easier to tune.

NOTE: Jetting is radically altered by different fuels. The new fuels nowadays can have Alcohol and or Oxygenated. Call Lectron for tips on rod changes.

Metering Rod Adjustment Chart

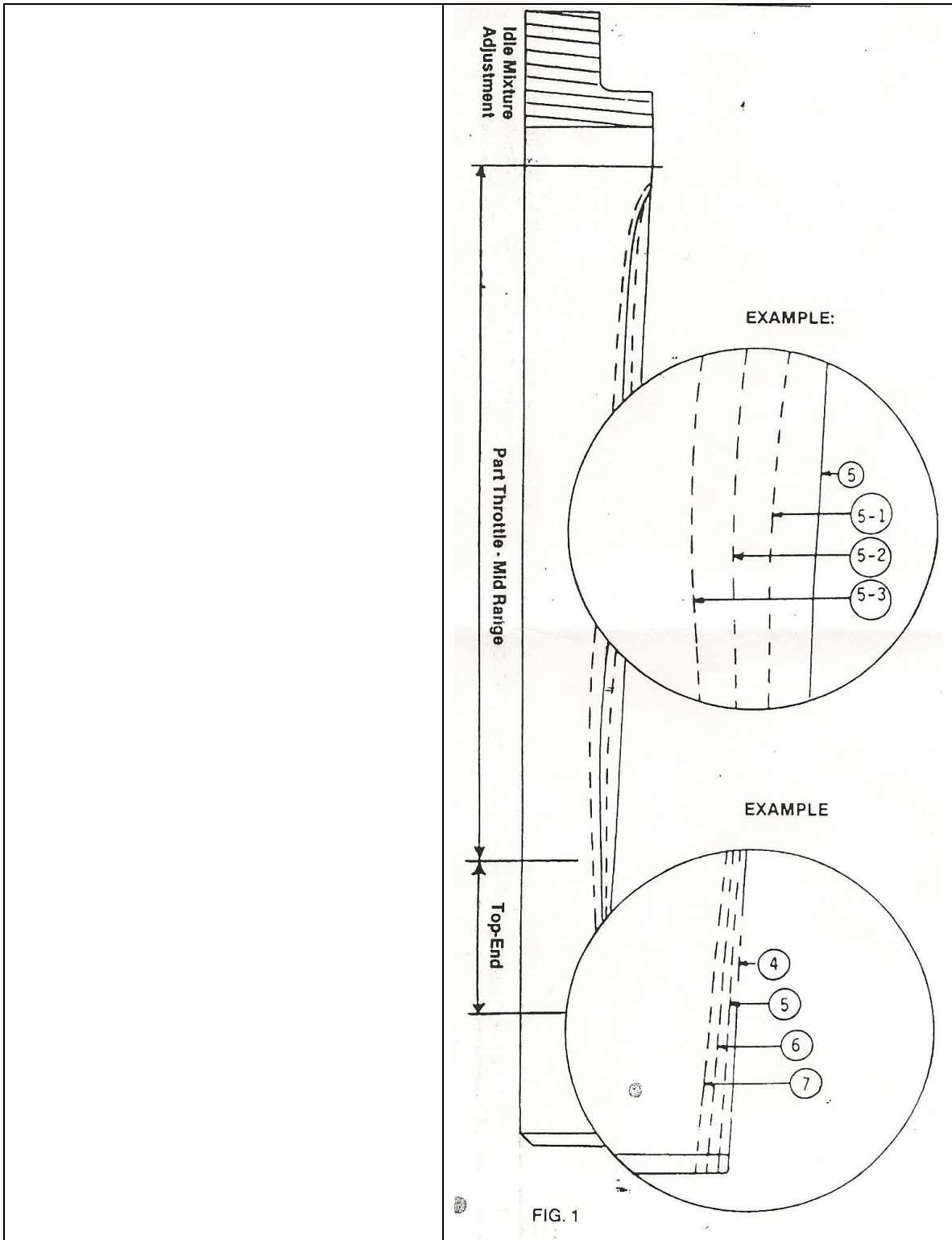

Initial Metering Rod Setting

The best way to achieve initial setting is to use a fuel ratio tool. This tool will actually measure the taper of the metering rod at an idle position. The fuel ratio tool is available for purchase from most of our Distributors and by Lectron Fuel Systems. If you do not have the fuel ratio tool you can achieve an initial setting using a set of veneer calipers to measure from the tip of the rod to the brass insert in the slide.

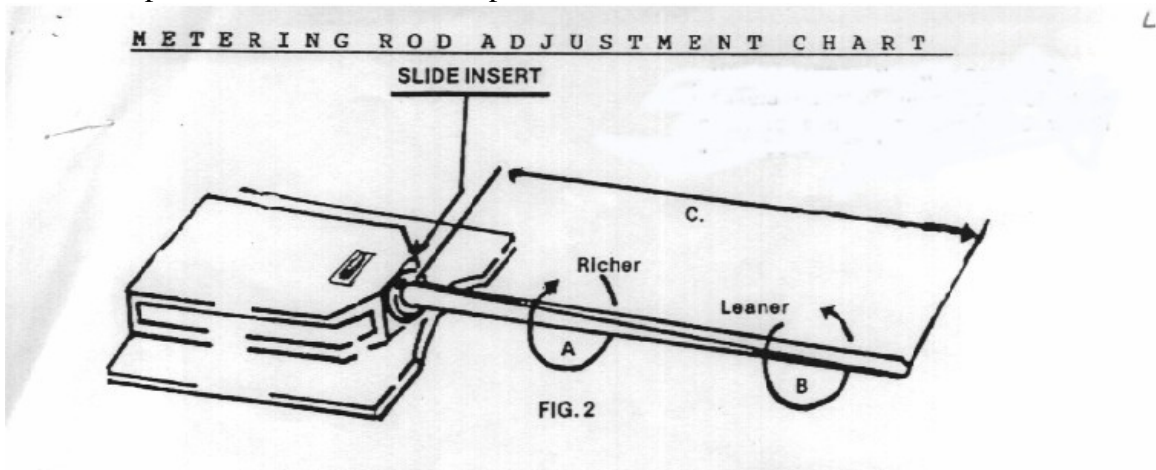

The metering rod that is supplied with your carburetor is recommended by the factory or the seller of the carb. When the carburetor is first sent to customers new the rod is pre-set for in its normal state of tune. If you have moved or are starting out with a new metering rod without a Fuel Ratio Tool a good standard measurement for an XL rod is 2.040" for a four stroke and 1.980" for a two stroke. Keep in mind these are generic settings and will only get you close. Any variations of tuning beyond the way that your engine was manufactured and subsequently maintained will effect the recommended selection and or setting of the metering rod. Including new type fuels that are oxygenated. NOTE: There are some out dated information out there on the internet about starting lengths and maximum and minimum lengths that the Lectron rod should be, do NOT pay attention to them the Lectron rods have changed in the past few years.

For fine LOW END tuning, turn the metering rod in direction of arrow "A" (richer) or "B" (leaner) as shown in Fig. 2 and rotate until flat side of rod is in position as shown. To do finer tuning you can move the metering rod in or out in 1/4 turn increments. EXAMPLE: To richen the mixture a small amount for low end. To do this simply screw the rod 1/4 turn in now you have shortened the rod and made it richer. Next you must adjust the flat side of the rod is facing the engine, grab the rod push in till you feel the spring collapse at the same time rotate the rod so the flat side is facing the engine and then let go. The rod will find its home in the slot and the rod will facing the engine. It's good to take a measurement very time you make a change so you know you are actually adjusting the rod. When you do this a few time it only takes seconds.

When purchasing a NEW “Pre-set” carburetor from Lectron there are still some variables in tuning. As you tune a Lectron Carburetor there are 3 basic steps you need to achieve.

Idle Adjustment

Start engine and try to get it up to operating temperature. Adjust the carburetor with idle screw to achieve a good stable idle about 1500-2000rpm. At this point give the throttle a couple of twists to check the response. If the engine seems to gurgle or stutter during accelerations it's probably too rich, and if it seems to wander or rev out of control it is probably too lean. When this condition occurs you need to adjust the rod. Note: with engine off observe the slide cutaway if the slide opening is very small it's a good chance you are too lean. If the slide cutaway is open very wide you are most likely too rich.

To achieve proper air fuel ratio you need to adjust the rod. Remove the three screws from the top of the carburetor and remove the slide and rod assembly. To richen the rod you need to make the rod shorter, and longer to lean it out. Use Lectron Metering rod adjusting tool to turn the rod in to shorten or out to lengthen. (PT#7000-1) To make a ¼ turn adjustment turn the rod one ¼ turn with the tool. **DO NOT PUSH UP ON THE ROD.** Now that you have turned the rod ¼ turn, the flat side of the rod does not face toward the engine anymore, you must now adjust the rod so it does. Use your fingers to achieve this adjustment. Simply grab the rod with your fingers and push up on the rod until you feel it bottom the spring and spin it back so the flat side of the rod faces the engine and then it drops down. You are done, you have made a ¼ turn adjustment. You can make as many adjustments as you want from ¼, ½, ¾, or full turns to achieve proper fuel ratio.

Multiple Carburetors

When working with two or more carburetors, it is necessary to make sure that the fuel ratio is the same. This is pre set and if you attempt to measure the length of the rods and compare them, they will not necessarily be equal. The only way to make sure your engine is getting equal amounts of fuel at idle is to purchase a fuel ratio tool and adjust them. If you need to adjust the rods different than factor set-up, **always** adjust the rods the same amount for each cylinder. Remember, the rods are pre-set to be equal when multiple carburetors are purchased.

Lectron Power jet Tuning

Operation:

The purpose of the Lectron Power jet or (adjustable main jet) is to supply fine tune top end with more fuel to the air under high air flow conditions. The power jet begins to meter fuel when the slide is more than 50% open (1/2 throttle). This allows the engine to run with leaner metering rods, which drastically improves the low-end to mid-range engine response, without damage to the engine. With the use of the Lectron power jet, it is now possible to richen the full throttle fuel-air mixture without changing the metering rod or disturbing low speed running.

Tuning Procedure:

After your low rpm response has been adjusted to suit your riding style (see Lectron tuning sheet), while the throttle response is nice and crisp, you're ready for high rpm tuning. This is the easiest part of tuning your Lectron. You will need an area that will allow you to get on the throttle for a few but no more than 5 seconds. Or if you are fortunate enough to get to a dyno this is the best way to get you engine perfect!

We will talk about tuning with a dyno and with out an O2 sensor.

If the engine starts to blubber, or four stroke, you will need to come down on the power jet size. If then engine comes on real crisp and starts to act as if it is running out of gas at high rpm you will need to go up on the power jet size. Make sure you take a plug reading (with a fresh plug) at the end of each pass. If the color of the plug is white or has blisters on the porcelain, then increase the power jet at least 2 to 3 sizes. The safest way to jet the top end is to go up on power jet size until the engine starts to blubber, then go down one size. The plug color you are looking for with pump gas is light tan. The color you are looking for with most race fuels is light gray.

Example: VM22-210 Pilot Jets Leaner #30---#50---#70 Richer

To change pilot jets, unscrew cap cover from power jet body. Using a fine blade screwdriver unscrew pilot jet from inside power jet body and remove. When replacing pilot jet, make sure it is seated firmly in the power jet body but do not over tighten or force. With adjustable power jet out for more fuel in for less.

How to Install Your Throttle Cable

- Step No. 1 - Remove all three of the top cover screws. No. 25 (see diagram)
- Step No. 2 - Remove top of carburetor, gasket, spring, and slide.
- Step No. 3 - Take the end of the throttle cable and start putting pieces on in this order.
(1) No. 27, weather seal; (2) No. 24, cover (cover will include No. 26, cable adjuster); (3) No. 23, gasket; (4) No. 32, slide spring (pull spring to a semi-collapsed position so there is about 1 ½" of cable sticking through); (5) No. 1, put cable end into slide and let spring bottom out in the large hole in the slide.
- Step No. 4 - Now you will have a single unit of all the pieces described above. Re-install into the carburetor body. This is very simple, the only thing to be careful with is to make sure the Fuel Metering Rod falls into the fuel outlet hole in the center of the carburetor body, you will know because the slide will not go all the way down. **DO NOT FORCE THE SLIDE.** If this problem should occur, the Fuel Metering Rod is not going into the hole. All you do to correct this problem is to look into the front of the carburetor and see where the Fuel Metering Rod must be moved to in order to line up with the hole. This can be done by pushing the rod with your finger until it drops into the hole.
- Step No. 5 - Put the three cover screws (No. 25) into the top cover of the carburetor and tighten down.
- Step No. 6 - Check the slack in the cable housing and adjust up with the cable adjuster (No. 26). Always leave about 1/8" slack in you cable to allow the slide to fully close from a full open position.
- Step No. 7 - Prior to starting engine, check the free travel of the slide by turning the throttle to a fully open and returning to a fully closed position. The slide should travel freely up and down in the carburetor body. If the slide does not travel freely and restriction is felt, **DO NOT USE.** There may be a problem with the spring not seating itself correctly due to incorrect installation. Repeat steps (1) through (6) again. If this fails to correct the problem please contact Lectron Fuel Systems, do not attempt to use the carburetor if slide restriction is encountered, as this could result in serious damage to you engine.

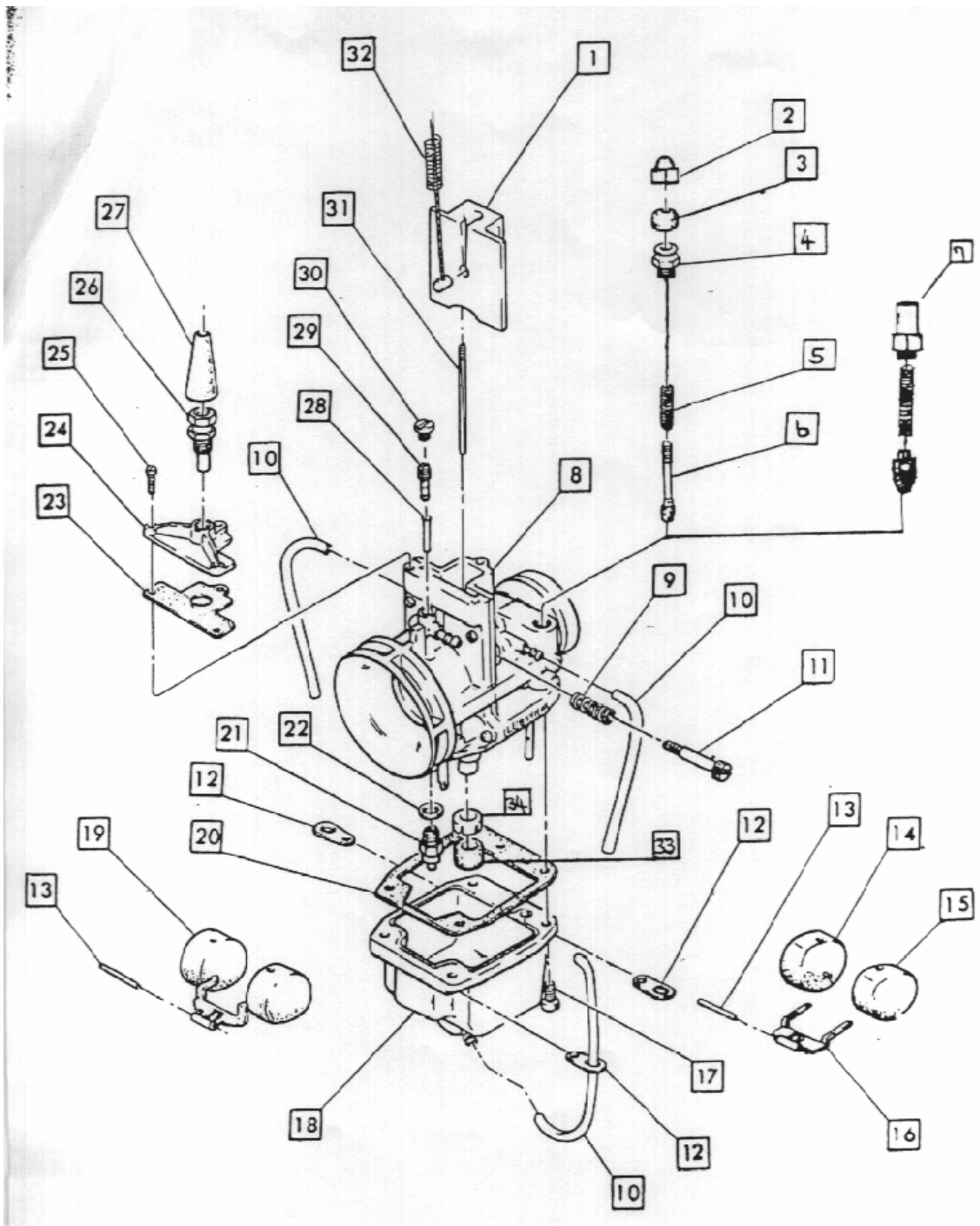

LECTRON PARTS LIST

<u>Part Name</u>	<u>Part #</u>	<u>Part Name</u>	<u>Part #</u>
1. Slide	5566-1	21. Needle & Seat Gravity	5034-1
2. New black pull knob	5593-3	22. Needle & Seat Gasket	5137-1
3. Choke Boot	5055-1	23. Top Cover Gasket	5077-1
4. Bushing Choke	5054-1	24. Top Cover Assembly	5018-1
5. Spring Choke	5048-1	25. Top Cover Screws (pkg. 3)	5089-1
6. Choke Piston with Tip	5045-1	26. Brass Cable Adjuster	5077-1
7. Cable Choke Assembly	5380-1	26. Metric Cable Adjuster	5335-1
8. Carburetor Body Only	N/A	27. Cable Weather seal	5061-1
9. Idle Stop Spring	5086-2	28. Power jet Nozzle (long)	5517-1
10. Vent Tube	5087-1	28. Power jet Nozzle (short)	5517-2
11. Idle Stop Screw	5057-1	29. Power jet	5467-1
12. Vent Clip - Tube	5062-1	30. Power jet Cap Screw & Gst	5466-1
13. Float Lever Pin	5033-1	31. Fuel Metering Rod	5400-1
14. Float Assembly L.H.	5028-3	32. Slide Spring (L, M, H)	5467-1
15. Float Assembly R.H.	5028-2	33. Fuel Screen	5366-1
16. Float Lever Ind. Floats	5023-1	34. Fuel Screen Encapsulator	5366-2
17. Float Bowl Screw (pkg.4)	5025-2		
18. Float Bowl Assembly	5584-1		
18. Float Bowl Assembly PJ	5584-2		
19. Dual Float Assembly	5565-1		
20. Float Bowl Gasket	5026-1		